



Operator's Manual

**Model/Serial Number
330100001101 & up**

Manufactured by
Regal Research and Mfg. Co.
1200 East Plano Parkway
Plano, TX 75074
Telephone: 800-898-3353
Fax: 972-272-0220
www.regalresearch.com

Notice

The Limited Warranty for owners of golf cars appears on the pages following this notice. The Limited Warranty for battery appears at the end of this manual. No other warranties, expressed or implied, are contained herein. Your authorized representative checked this vehicle before it was delivered to you.

Regal Research is not liable for errors in this manual or for incidental or consequential damages that result from the use of the material in this manual.

This vehicle conforms to applicable portions of the current American National Standards Institute's Z130 Safety and Performance Requirements for Golf Cars. This standard, which promotes safety in the design, application, and operation of golf cars, defines a golf car as "a vehicle used to convey a person or persons and equipment to play the game of golf in an area designated as a golf course." Throughout this manual, the words "golf car" and "vehicle" are used interchangeably.

This manual contains proprietary information that is protected by copyright. All rights are reserved. No part of the manual may be photocopied, reproduced, or translated to another language without the written consent of Regal Research and Mfg. Co. The information contained in this document is subject to change without notice.

Regal Research reserves the right to make design changes to vehicles without obligation to make these changes on units previously sold.

These vehicles do not conform to Federal Motor Vehicle Safety Standards for automobiles or to FMVSS 500 for low-speed vehicles, and are not equipped for operation on public streets, roads, or highways.

Limited Warranty

Subject to the provisions hereof, Regal Research and Mfg. Co. ("Regal Research"), the Manufacturer, warrants to the original Purchaser this SoloRider product to be free from defects in materials or workmanship for periods stated below from the date of purchase under normal use with normal maintenance service, provided that said Purchaser gives written notice to Manufacturer of any claimed defect within stated periods after the date of purchase and Manufacturer determines to its reasonable satisfaction that the product was defective when purchased. The sole remedy for any defect in the product is repair of the product or replacement of the product if repair is not possible or feasible in the sole judgment of the Manufacturer. The costs of parts and labor are included, but the purchaser must pay any transportation costs.

THIS LIMITED WARRANTY DOES NOT COVER routine maintenance, normal wear items, or damage from misuse, abuse, or failure to perform routine maintenance. Routine service required to keep this warranty in force is at the Purchaser's expense. BATTERIES AND TIRES ARE NOT COVERED under this warranty; their manufacturer warrants them directly. THIS WARRANTY DOES NOT COVER any product or part that has been altered, modified, or reworked, nor does it cover any part that was not supplied by Manufacturer. THIS LIMITED WARRANTY DOES NOT COVER losses or damages that occur as a result of shipping, improper installation or maintenance by anyone other than Manufacturer, acts of God or accident, misuse, neglect or misapplication of the product.

THIS LIMITED WARRANTY IS IN LIEU OF ALL OTHER WARRANTIES, WHETHER ORAL OR WRITTEN, EXPRESSED OR IMPLIED. THERE ARE NO WARRANTIES OF MERCHANTABILITY OR FITNESS FOR A PARTICULAR PURPOSE. TO THE EXTENT THAT ANY IMPLIED WARRANTY IS RECOGNIZED BY APPLICABLE LAW DESPITE THE FOREGOING DISCLAIMER, SUCH IMPLIED WARRANTY IS LIMITED IN DURATION TO A PERIOD OF ONE (1) YEAR FROM THE DATE OF PURCHASE.

MANUFACTURER'S OBLIGATIONS AND PURCHASER'S REMEDIES HEREUNDER ARE SOLELY AND EXCLUSIVELY AS STATED HEREIN, WHETHER BASED ON CONTRACT, TORT, WARRANTY, STRICT LIABILITY, OR ANY OTHER THEORY, AND MANUFACTURER'S LIABILITY SHALL NOT EXCEED THE PRICE OF THE INDIVIDUAL PRODUCT WHOSE DEFECT IS THE BASIS FOR THE CLAIM. IN NO EVENT SHALL MANUFACTURER BE LIABLE FOR ANY LOSS OF PROFITS, LOSS OF USE OF FACILITIES OR EQUIPMENT, OR OTHER INCIDENTAL OR CONSEQUENTIAL DAMAGES, INCLUDING ANY COST OR EXPENSE OF PROVIDING SUBSTITUTE EQUIPMENT DURING THE PERIOD OF NON-USE PENDING COMPLETION OF REPAIRS UNDER THIS LIMITED WARRANTY. This Limited Warranty is solely for the benefit of the original Purchaser. Said Purchaser's rights hereunder may not be assigned to any other person, and nothing contained herein shall be construed to confer rights on any third party.

TO OBTAIN PERFORMANCE UNDER THIS LIMITED WARRANTY the Purchaser must obtain service at a service center authorized by Manufacturer. A written receipt for the product showing the date of purchase, and both the model number and serial number, must accompany any request or claim for work to be performed. To find an authorized service center nearest to you, please call our toll free number, (800) 898-3353, and ask for "Service."

LIMITED WARRANTY PERIODS

Frame	5 Years
Drive Train	3 Years
Batteries & Tires	are not covered *
All other	1 Year

*Batteries and tires are covered by their manufacturers. See separate limited warranty agreements.

Practice Safety



Safety signs like you see above may at first seem shocking, but their impact is mild compared with the reality of severe personal injury.

Your safety and satisfaction are of the utmost importance to Regal Research. That is why before operating the vehicle, we urge you to review the information in this manual.

Understand and become familiar with the DANGER, WARNING, and CAUTION statements and procedures it contains, along with the safety decals that are affixed to your vehicle.

Take time to understand the language of safety. It is a language that can save your life.

TABLE OF CONTENTS

<u>Subject</u>	<u>Page #</u>
Safety Details	6
General Warnings	7
Vehicle Feature Identification	8
General Information	9
Model Identification	9
Safety Committee	9
Pre-Operation Checklist	10
Controls and Indicators	11
Driving Instructions	15
Towing	17
Transporting on a Trailer	18
Storage	19
Maintenance	20
Daily Pre-Operation Safety Checklist	20
Periodic Service Schedule	21
Periodic Lubrication Schedule	23
Vehicle Capacities	24
Vehicle Controller	24
Batteries	24
Battery Charger	27
Cleaning the Vehicle	32
Accessories	33
Vehicle Specifications	34

Attachment: US Battery Warranty

Safety Details

WARNING

THIS OWNER'S MANUAL SHOULD BE READ COMPLETELY BEFORE ATTEMPTING TO DRIVE OR SERVICE THE VEHICLE. FAILURE TO FOLLOW THE INSTRUCTIONS IN THIS MANUAL COULD RESULT IN PROPERTY DAMAGE, SEVERE PERSONAL INJURY, OR DEATH.

It is important to note that some vital statements throughout this manual and on the decals affixed to the vehicle are preceded by the words DANGER, WARNING, CAUTION, or NOTE. For your protection, we recommend that you take special notice of these safety procedures. Safety procedures are essential and must be followed.

Throughout this manual and on the operation and warning decals affixed to the vehicle, the words "golf car" and "vehicle" are used interchangeably. "Golf car" is defined in the Notice of this manual and no other representation is stated or implied.

If any of the operation or warning decals on the vehicle become damaged, have been removed or cannot be easily read, they should be replaced immediately to avoid possible property damage, personal injury, or death. Contact your SoloRider distributor/dealer.

DANGER

A DANGER INDICATED AN IMMEDIATE HAZARD THAT WILL RESULT IN SEVERE PERSONAL INJURY OR DEATH.

WARNING

A WARNING INDICATED AN IMMEDIATE HAZARD THAT COULD RESULT IN SEVERE PERSONAL INJURY OR DEATH.

CAUTION

A CAUTION INDICATES HAZARDS OR UNSAFE PRACTICES THAT COULD RESULT IN MINOR PERSONAL INJURY OR PRODUCT OR PROPERTY DAMAGE.

NOTE

A NOTE PROVIDES KEY INFORMATION TO MAKE PROCEDURES MORE EASILY UNDERSTOOD.

General Warnings

The safety procedures listed must be followed whenever the vehicle is being operated, repaired, or serviced. Vehicle feature identification information is also included. Other specific WARNING statements appear throughout this manual and on the vehicle.

DANGER

- BATTERY VAPORS – FLAMMABLE! EXPLOSIVE! DO NOT SMOKE. KEEP SPARKS AND FLAMES AWAY FROM VEHICLE AND SERVICE AREA. SERVICE ONLY IN WELL-VENTILATED AREAS.
- A GOLF CAR WILL NOT PROVIDE PROTECTION FROM LIGHTNING, FLYING OBJECTS, OR OTHER STORM RELATED HAZARDS. IF CAUGHT IN A STORM WHILE DRIVING A GOLF CAR, EXIT THE VEHICLE AND SEEK SHELTER IN ACCORDANCE WITH APPLICABLE SAFETY GUIDELINES FOR YOUR LOCATION.

WARNING

- DO NOT LEAVE CHILDREN UNATTENDED ON VEHICLE.
- WHEN STOPPING AND LEAVING THE VEHICLE, ALWAYS TURN THE KEY SWITCH TO **OFF** AND REMOVE THE KEY.
- ONLY TRAINED TECHNICIANS SHOULD REPAIR OR SERVICE THE VEHICLE. ANYONE DOING EVEN SIMPLE REPAIRS OR SERVICE SHOULD FOLLOW THE PROCEDURES EXACTLY AS STATED IN THIS MANUAL, AND FOLLOW ALL **DANGER, WARNING, AND CAUTION** PROCEDURES LISTED IN THIS MANUAL AS WELL AS THOSE AFFIXED TO THE VEHICLE.
- WEAR SAFETY GLASSES OR APPROVED EYE PROTECTION WHEN SERVICING THE VEHICLE. WEAR A FULL FACE SHIELD AND RUBBER GLOVES WHEN WORKING WITH BATTERIES.
- USE INSULATED TOOLS WHEN WORKING AROUND BATTERIES OR ELECTRICAL CONNECTIONS. IMPROPER USE OF THE VEHICLE OR FAILURE TO PROPERLY MAINTAIN IT, COULD RESULT IN DECREASED VEHICLE PERFORMANCE, OR SEVERE PERSONAL INJURY.
- ANY MODIFICATION OR CHANGE TO THE VEHICLE THAT AFFECTS THE STABILITY OR HANDLING OF THE VEHICLE, OR INCREASES MAXIMUM VEHICLE SPEED BEYOND FACTORY SPECIFICATIONS, COULD RESULT IN SEVERE PERSONAL INJURY OR DEATH.
- PRIOR TO SERVICING THE VEHICLE, CHOCK THE WHEELS, TURN THE KEY SWITCH TO **OFF**, AND REMOVE THE KEY, PLACE TOW/OFF/RUN SWITCH IN THE **OFF** POSITION BEFORE DISCONNECTING BATTERIES. DISCONNECT THE BATTERY CABLES, NEGATIVE (-) FIRST.
- TO AVOID UNINTENTIONALLY STARTING THE VEHICLE, DISCONNECT THE BATTERIES BEFORE SERVICING.

WARNING

ROLLOVER OR FALLING OFF MAY CAUSE SEVERE INJURY OR DEATH.

- Before using vehicle, read operating instructions.
- Fasten seat belt before operating vehicle.
- Remain seated and hold on to floor while moving.
- Keep entire body inside vehicle while moving.
- Operate from driver's position only and not on public roads.
- One person maximum per vehicle.
- Do not start vehicle until fully seated.
- Drive slowly in turns and straight up and down slopes.
- Never operate under the influence of alcohol or drugs.
- Do not leave children unattended on vehicle.
- Never stand in front of or behind vehicle.
- Operate in designated areas only.

OPERATING INSTRUCTIONS

- Read Operator's Manual and safety warnings located on top panel prior to driving.
- Study and understand controls.

TO START VEHICLE

- Make sure wheels are turned in desired direction.
- Turn key to "ON" position and be sure nothing is in your path.
- While vehicle is stopped, select desired direction by placing switch in Forward or Reverse (Buzzer will sound).

TO OPERATE VEHICLE

- Vehicle will move when right or left accelerator thumb lever is depressed.
- Slowly depress either accelerator lever to increase speed.
- Park brake will release when accelerator lever is depressed.

TO STOP VEHICLE

- To stop, release accelerator levers and apply both brake hand levers.
- After stopping, park brake will automatically engage after a momentary delay.
- Turn key "OFF". Park brake will immediately engage.
- Remove key when not in use.

50051

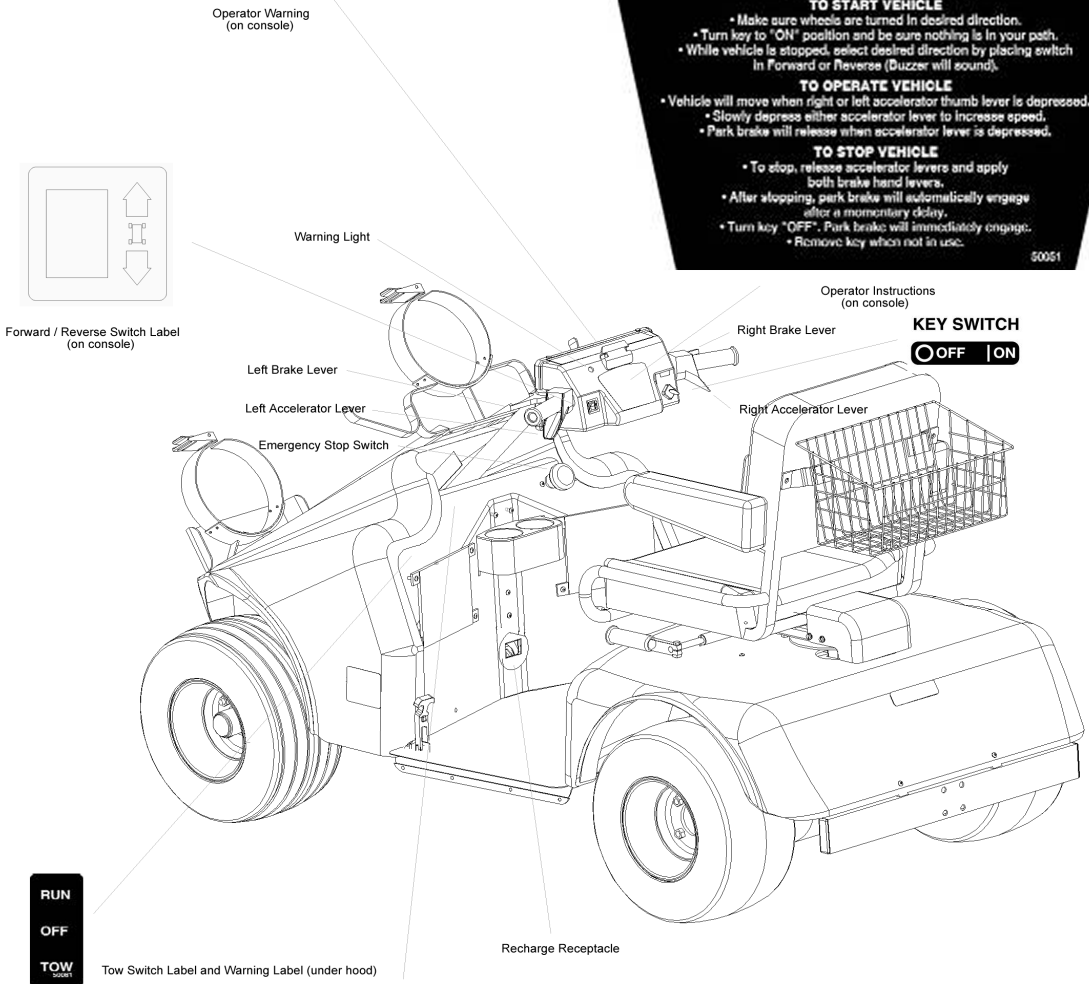

RUN

OFF

TOW

WARNING

IMPROPER TOW SWITCH POSITION MAY CAUSE VEHICLE DAMAGE, PERSONAL INJURY, OR DEATH.

- Before towing, select "TOW" position which will release park brake.
- Select "OFF" position before disconnecting batteries, servicing vehicle, or extended storage.
- Must be in "RUN" position for vehicle operation.

50059

NOTICE

- DO NOT OPERATE VEHICLE WITHOUT COVER IN PLACE.
- DO NOT DIRECT WATER STREAM AT THIS SWITCH.

CCI 1016109-01

POTENTIOMETER DECAL

(Under hood)

BATTERY DANGER (ON BATTERY CAPS)

DANGER / POISON

SHIELD EYES EXPLOSIVE GASES CAN CAUSE BURNING OF EYES	NO • SPARKS • FLAMES • SMOKING	SULFURIC ACID • CAN CAUSE BLINDNESS OR SEVERE BURNS	FLUSH EYES IMMEDIATELY WITH WATER GET MEDICAL HELP FAST
---	--	---	--

KEEP OUT OF THE REACH OF CHILDREN - DO NOT TIP - KEEP VENT CAPS TIGHT AND LEVEL

General Information

Throughout this manual, important features are highlighted. We urge the owner/operator to read and understand this manual, and to pay special attention to the features specific to his/her vehicle(s).

Model Identification

The serial number of your SoloRider is printed on a decal mounted on the frame behind the front battery receptacle. (Figure 1). See following NOTE.

NOTE

ALWAYS HAVE THE VEHICLE SERIAL NUMBER AT HAND WHEN ORDERING PARTS OR MAKING INQUIRIES.

Serial Number Location

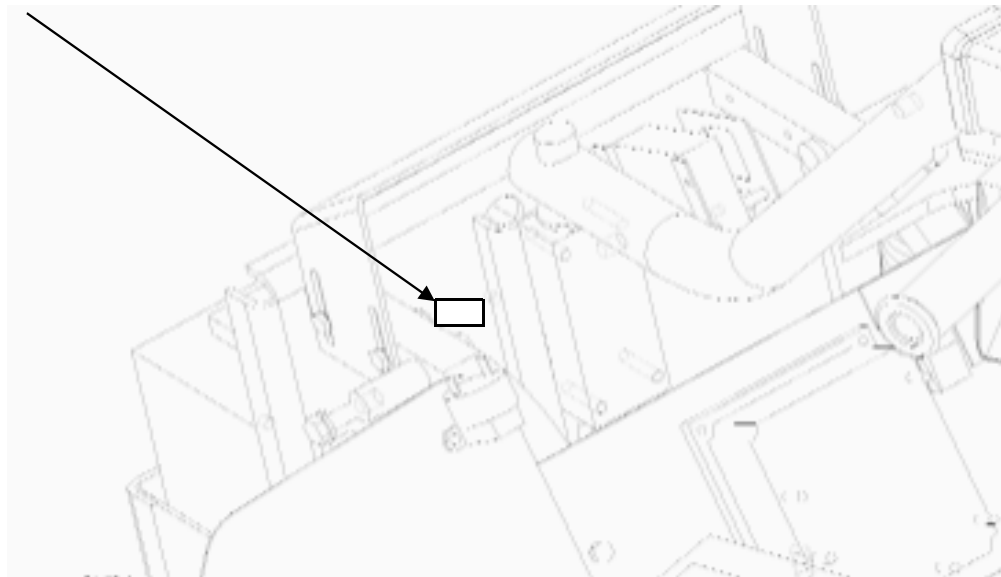

Figure 1

Safety Committee

If the golf car is to be rented or is part of a fleet, we strongly recommend that a safety committee be appointed. One of the main concerns of this committee should be the safe operation of the golf cars.

This should include at a minimum:

- Where golf cars should be driven.
- Ensuring that proper warnings of driving hazards are displayed and visible.
- Who should and who should not drive golf cars.
- Instructing first time drivers.
- Maintaining golf cars in a safe driving condition.
- How various rules are to be enforced.

The safety committee should include all these items and such others, as the committee feels necessary or appropriate.

Pre-Operation Checklist

Your SoloRider has been thoroughly inspected and adjusted at the factory. However, upon arrival of your new SoloRider (s), you should become familiar with its controls and operation, and carefully inspect each vehicle to be satisfied that it is in proper working condition before accepting delivery.

Use the following checklist as a guide to inspect your new vehicle. This same checklist should also be used in conjunction with the Periodic Service Schedule. Only your SoloRider distributor/dealer or a trained technician should correct any problems.

- **General:** All the parts should be in place and properly installed. Be sure that all nuts, bolts, and screws are tight.
- **Warning Decals:** Check to ensure that all warning and operation decals are in place.
- **Tires:** Check for proper tire pressure. (See Vehicle Capacities).
- **Batteries:** Check electrolyte to ensure that it is at its proper level (figure 6). Check battery posts. Wires should be tight and free of corrosion. Charge batteries fully before first use of vehicle.

Performance Inspection

After you have familiarized yourself with the vehicle's controls and have read and understood the driving instructions, take the vehicle for a test drive. Use the following checklist as a guide to inspect your new vehicle. Only your SoloRider distributor/dealer or a trained technician should correct any problems.

ALL VEHICLES:

Brakes: Be sure the brakes function properly. When brake levers are fully depressed under moderate pressure, each lever should not go more than halfway to the handgrip, and vehicle should come to a smooth, straight stop within 14 feet (427 cm). If a lever goes more than halfway to the handgrip or if the vehicle swerves or fails to stop within 14 feet (427 cm), have the brake system checked and adjusted as required. Brake adjustment must be maintained so that the brake lever cannot be depressed to the handgrip under any circumstance.

Park Brake: The park brake should lock and hold the vehicle stationary (on incline of 20% or less). It should release when the accelerator is depressed when the key switch is ON.

Reverse Buzzer: The reverse buzzer will sound as a warning when the Forward/Reverse switch is in REVERSE when the key switch is ON.

Steering: The vehicle should be easy to steer and should not have any play in the steering tiller.

Accelerator: With the key switch ON and the Forward/Reverse switch in the FORWARD position, as the accelerator lever is depressed, the motor should start, and the vehicle should come up smoothly to full speed. When the accelerator is released, it should return to the original position and the motor should stop. All vehicles operate at a reduced speed in reverse.

General: Listen for any unusual noises such as squeaks or rattles. Check the vehicle's ride and performance. Have a SoloRider distributor/dealer or a trained technician investigate anything unusual.

“Pedal Up” Motor Braking: Accelerate the vehicle to full speed and then release the accelerator lever. Motor braking should smoothly slow the vehicle to a gradual stop.

“Pedal Down” Motor Braking: Accelerate down an incline with the accelerator lever depressed. When the vehicle reaches set top speed, motor braking should engage and moderate vehicle speed between 12 and 15 mph, depending upon the grade of the hill.

Controls and Indicators

Read DANGER and WARNING

WARNING

- IF RENTING OR LOANING THE VEHICLE, MAKE SURE THE DRIVER IS FAMILIAR WITH ALL CONTROLS AND OPERATING PROCEDURES BEFORE ALLOWING THE VEHICLE TO BE DRIVEN.
- DO NOT MODIFY OR CHANGE THE VEHICLE IN ANY WAY WHICH MIGHT AFFECT ITS STABILITY OR HANDLING, OR INCREASE MAXIMUM SPEED BEYOND FACTORY SPECIFICATIONS. PROPERTY DAMAGE, PERSONAL INJURY, OR DEATH COULD RESULT.
- DO NOT SHIFT THE FORWARD/REVERSE (F & R) SWITCH WHILE THE VEHICLE IS MOVING. TO AVOID INJURY OR DAMAGE TO THE VEHICLE, ALWAYS BRING THE VEHICLE TO A FULL STOP BEFORE SHIFTING THE F & R SWITCH.
- RELEASE THE ACCELERATOR LEVER AND THEN DEPRESS THE BRAKE LEVERS FIRMLY UNTIL THE VEHICLE STOPS. TO AVOID UNINTENTIONALLY STARTING OR ROLLING THE VEHICLE, TURN THE KEY SWITCH TO OFF, AND REMOVE THE KEY WHEN LEAVING THE VEHICLE.

Key Switch

The key switch is mounted on the console (Figure 2). It has two (2) positions, OFF and ON, which are clearly labeled. See following NOTE.

NOTE

- THE KEY CAN BE REMOVED WHEN THE KEY SWITCH IS IN THE OFF POSITION ONLY.

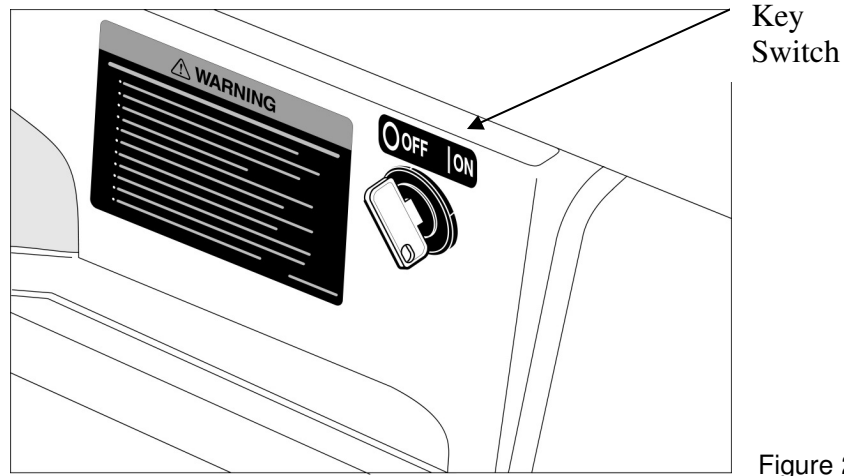

Figure 2

Forward/Reverse Control

The Forward/Reverse (F&R) switch is located on the steering console, (Figure 3). The F&R switch has two distinct positions: UP (FORWARD) and DOWN (REVERSE). The reverse buzzer will sound and a warning when the Forward/Reverse switch is in REVERSE and the key switch is on.

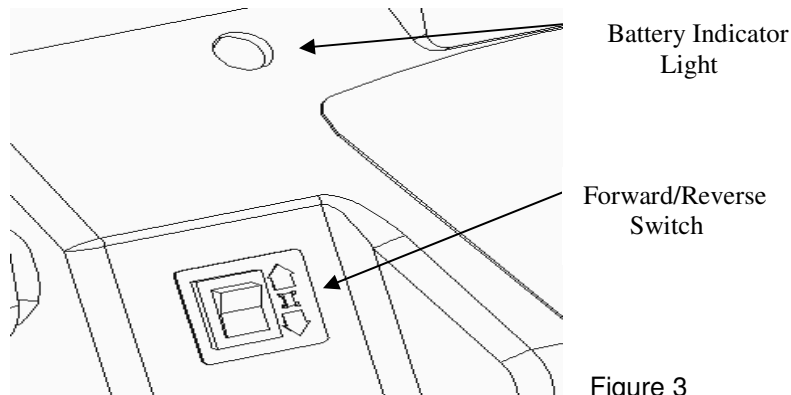

Figure 3

Accelerator and Brake Levers (Right Side Only Shown)

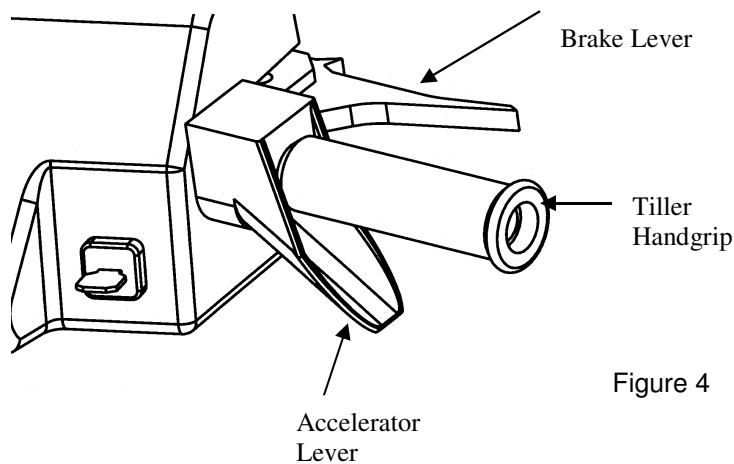

Figure 4

Accelerator Levers

The accelerator levers are the levers on the bottom of the tiller handgrip (Figure 4). The operation of the accelerator lever differs from that of an automobile. When the key switch is ON, and the Forward/Reverse switch is in either FORWARD or REVERSE, depressing either accelerator lever will automatically release the park brake and start the vehicle moving in the direction selected (forward or reverse). As the accelerator lever is depressed, speed will increase until full speed is reached. When the accelerator is released, motor braking will gently slow the vehicle.

Brake Levers

The brake levers are the levers on the front side of the tiller handgrips (Figure 4). To slow or stop the vehicle, depress both of the brake levers (Figure 4). The brake levers actuate individual rear brakes, e.g. the right brake lever actuates the right rear brake, and the left brake lever actuates the left rear brake. The individual actuation of the brakes can be used as a manual traction control to allow the vehicle to drive out of a situation where one drive wheel tends to slip. In this situation, apply light pressure to the brake lever for the wheel that is slipping. This will transfer some of the tractive effort to the other wheel, which should result in the vehicle driving out of the situation.

Parking Brake

The parking brake is automatically applied whenever the vehicle comes to a stop or whenever the key switch is turned to OFF. See following WARNING.

WARNING

THE PARKING BRAKE WILL RELEASE AUTOMATICALLY WHEN EITHER ACCELERATOR LEVER IS DEPRESSED AND THE KEY IS "ON."

Warning Light

The vehicles feature a console mounted warning light that, when the vehicle is in operation, indicates low battery voltage. The onboard computer controls the battery warning light. When the vehicle is in operation, the warning light will illuminate and blink 32 times, pause and repeat, if the batteries have discharged to less than approximately 20% of their capacity. If the warning light illuminated when the vehicle is operating, there will be enough power remaining to drive the vehicle for approximately 10 minutes. However, the vehicle should be charged at the first opportunity. If the warning light illuminates and the vehicle is unable to operate for 10 minutes, or if the warning light blinks a different number of times, have your SoloRider distributor/dealer check the vehicle for a possible battery or electrical system problem.

Emergency Stop Switch (Optional)

In the event of an emergency, the E-Stop Switch (Figure 2A) may be pushed. Pushing the E-stop switch will disconnect all electrical power to the vehicle, immediately apply the parking brake and quickly stop the vehicle motion. Cycle the switch periodically to ensure proper operation.

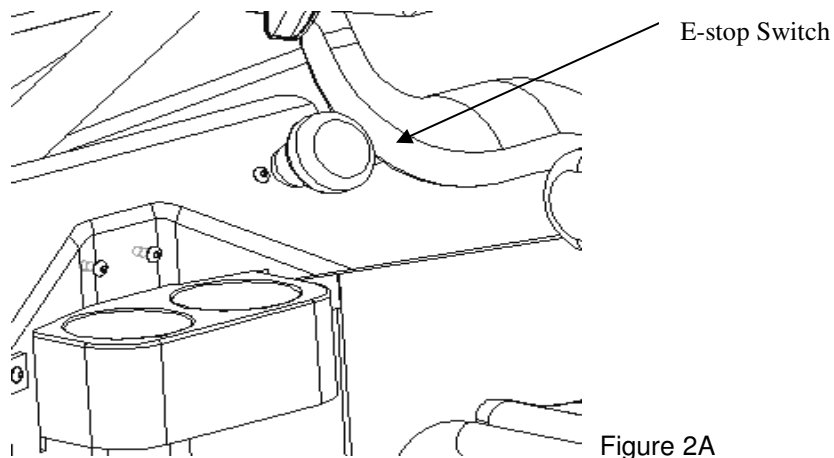
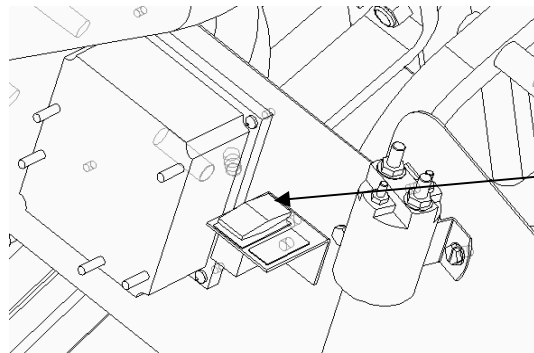

Figure 2A

Tow/Off/Run Switch

⚠ WARNING

- TO AVOID POSSIBLE BATTERY EXPLOSION, THE TOW/OFF/RUN SWITCH MUST BE IN THE **OFF** POSITION BEFORE DISCONNECTING OR CONNECTING BATTERY WIRES.
- WHEN THE TOW/OFF/RUN SWITCH IS IN THE **TOW** POSITION, ALL MOTOR BRAKING FUNCTIONS ARE DISABLED AND THE PARKING BRAKE IS DISABLED.



Tow/Off/Run Switch

Figure 5

Tow/Off/Run Switch

The vehicles are equipped with a Tow/Off/Run Switch, located under the front body near the onboard controller (Figure 5). The switch must be in the RUN position in order to operate the vehicle. When the switch is in the OFF position, power to the vehicle electrical components is turned off and the vehicle will not operate. When the switch is in the TOW position, battery voltage is applied to the parking brake, causing it to release. See following NOTE.

When the Tow/Off/Run switch is in the TOW position, the parking brake is disabled. Place the Tow/Off/Run switch in the TOW position only while absolutely required, to avoid having the vehicle unexpectedly roll away. When the Tow/Off/Run switch is in the TOW position, battery voltage is applied to the parking brake to release it. Leaving the Tow/Off/Run switch in the TOW position will cause the batteries to discharge.

NOTE

- The Tow/Off/Run switch should be placed in the **TOW** position only under the following conditions:
 - **Before Towing the Vehicle** – Place the Tow/Off/Run switch in the TOW position to disable all motor braking functions, thus preventing possible damage that could occur to the vehicle or electrical components if the vehicle is towed while the Zero-Speed Detect motor braking function is operating.
- The Tow/Off/Run switch should be placed in the **OFF** position under the following conditions:
- **Before Disconnecting or Attaching Battery Wires** – Place the Tow/Off/Run switch in the OFF position to turn off power to the vehicle electrical system, thus preventing severe arcing and possible battery explosion as the battery wires are disconnected.
 - **For Long Term Storage** – Place Tow/Off/Run switch in the **OFF** position to turn off power to the vehicle electrical system, thus preventing vehicle electrical components from discharging the batteries.

WARNING

Driving Instructions

- ONLY LICENSED DRIVERS SHOULD BE ALLOWED TO DRIVE THIS VEHICLE.
- IF RENTING OR LOANING THE VEHICLE, MAKE SURE THE DRIVER IS FAMILIAR WITH ALL CONTROLS AND OPERATING PROCEDURES BEFORE ALLOWING THE VEHICLE TO BE DRIVEN.
- NO MORE THAN ONE (1) PERSON SHOULD BE ON THE VEHICLE AT ONE TIME.
- THE VEHICLE IS SPECIALLY EQUIPPED FOR PERSONS WITH DISABILITIES. HOWEVER, THERE IS NO GUARANTEE THAT THE VEHICLE WILL ACCOMMODATE ANY PARTICULAR PERSON'S DISABILITY.
- BE SURE ALL PERSONS CAN PROPERLY OPERATE THE VEHICLE PRIOR TO ALLOWING THEM TO DRIVE THE VEHICLE.
- BE SURE ALL PASSENGERS ARE CAPABLE OF SECURING THEMSELVES IN A MOVING VEHICLE BEFORE ALLOWING THEM TO RIDE IN ONE.
- FOR NIGHT USE, THE VEHICLE MUST BE EQUIPPED WITH HEADLIGHTS, TAILLIGHTS, AND REFLECTORS.
- STOP THE VEHICLE BEFORE SHIFTING THE FORWARD/REVERSE SWITCH. FAILURE TO DO SO MAY RESULT IN INJURY AND (OR) DAMAGE TO THE VEHICLE.

Warnings Continued next page

- TO AVOID BEING STRUCK, DO NOT STAND IN FRONT OR BEHIND THE VEHICLE.
- OPERATE THE VEHICLE FROM THE DRIVER SEAT ONLY.
- TO PREVENT FALLS FROM THE VEHICLE, REMAIN SEATED IN A MOVING VEHICLE AND HAVE SEAT AND CHEST BELTS FASTENED AT ALL TIMES. DRIVER SHOULD KEEP BOTH HANDS ON THE STEERING TILLER WHEN THE VEHICLE IS IN MOTION.
- TO PREVENT THE POSSIBILITY OF SERIOUS INJURY, KEEP YOUR ENTIRE BODY INSIDE THE VEHICLE.
- DO NOT LEAVE CHILDREN UNATTENDED ON VEHICLE.
- TO PREVENT OVERTURNING THE VEHICLE, DRIVE SLOWLY STRAIGHT UP AND DOWN SLOPS. **AVOID DRIVING THE VEHICLE ON SLOPES EXCEEDING 20% INCLINE.**
- TO AVOID POSSIBLE INJURY AND (OR) DAMAGE TO THE VEHICLE, AVOID SUDDEN STARTS, SUDDEN STOPS, AND ABRUPT TURNS.
- TO AVOID THE POSSIBILITY OF LOSING CONTROL OF OR OVERTURNING THE VEHICLE, REDUCE SPEED FOR ADVERSE DRIVING CONDITIONS SUCH AS WET GRASS OR ROUGH TERRAIN.
- DO NOT USE THE VEHICLE ON PUBLIC ROADS. IT IS NOT DESIGNED OR INTENDED FOR STREET USE AND SHOULD NOT BE LICENSED FOR USE ON PUBLIC ROADS.
- OBEY ALL LOCAL RULES CONCERNING GOLF CARS.
- TRAINED DRIVERS SHOULD DRIVE THE VEHICLE IN ONLY SPECIFIED AREAS.
- DO NOT DRIVE WHILE UNDER THE INFLUENCE OF ALCOHOL, DRUGS, OR MEDICATIONS.
- TO PREVENT OVERTURNING THE VEHICLE, DRIVE SLOWLY IN TURNS.
- USE BRAKES TO REDUCE SPEED WHEN COASTING DOWNHILL.

No one should drive the vehicle without first being instructed in the proper operation and use of the vehicle's controls. An experienced operator should accompany each first-time driver on a test drive before allowing him/her to operate the vehicle alone.

To ensure safe operation of the vehicle, follow exactly and in order, all of the following procedures. Read and understand all instruction prior to driving the vehicle.

Starting the Vehicle

- Study and understand the controls.
- Make sure the driver is seated and secured with waist and chest belts.
- Read safety warnings located on dash and (or) console.
- Make sure wheels are turned in desired direction.
- Turn key to the ON position and make sure nothing is in your path.
 - Select a direction by placing Forward/Reverse switch in desired position (Forward or Reverse). A buzzer will sound as a warning when the Forward/Reverse switch is in REVERSE.

- Slowly depress accelerator lever (s). The park brake will release automatically and the vehicle will start to move. As the accelerator lever (s) are depressed, speed will increase until full speed is reached. **See following WARNING.**

⚠ CAUTION

WHEN STOPPED ON A HILL, USE THE BRAKES TO HOLD YOUR POSITION. DO NOT USE THE ACCELERATOR LEVERS.

⚠ WARNING

- THE DRIVER MUST CONTROL VEHICLE SPEED WHEN GOING DOWNHILL.
- “PEDAL DOWN” OR “PEDAL UP” MOTOR BRAKING MAY BE USED TO HELP CONTROL SPEED WHEN GOING DOWNHILL. (SEE PERFORMANCE INSPECTION ON PAGE 10). HOWEVER, TERRAIN OR OTHER CONDITIONS MAY REQUIRE THAT MANUAL BRAKING BE USED IN CONJUNCTION WITH MOTOR BRAKING.

Stopping the vehicle

⚠ WARNING

DRIVING THROUGH WATER MAY AFFECT THE BRAKES. AFTER DRIVING THROUGH WATER, CHECK EFFECTIVENESS OF THE BRAKES BY GENTLY DEPRESSING THE BRAKE LEVERS. IF THE VEHICLE DOES NOT SLOW DOWN AT THE NORMAL RATE, CONTINUE TO DEPRESS THE BRAKE LEVERS UNTIL THE BRAKES DRY OUT AND NORMAL PERFORMANCE RETURNS.

To stop the vehicle, release the accelerator levers, and depress the brake levers until the vehicle comes to a complete stop.

Parking and leaving the vehicle

After stopping the vehicle, the parking brake will automatically apply after approximately one second. This will prevent the vehicle from rolling.

Turn the key switch to OFF. Remove the key when the vehicle is not in use.

Towing

⚠ WARNING

- NEVER TOW THE VEHICLE ON PUBLIC STREETS OR HIGHWAYS.
- USE ONLY APPROVED SOLORIDER TOW BARS.
- TURN THE KEY SWITCH TO OFF AND PLACE THE TOW/OFF/RUN SWITCH IN **TOW** BEFORE TOWING THE VEHICLE.

WARNINGS CONTINUED NEXT PAGE

- EXTREME CAUTION SHOULD BE USED WHEN TOWING ANY VEHICLE.
- DO NOT EXCEED 5 MPH (8KM/H) TOWING SPEED.

- DO NOT ALLOW PEOPLE IN THE VEHICLES BEING TOWED.
- AVOID SUDDEN STARTS, SUDDEN STOPS, AND TIGHT TURNS WHEN TOWING.
- DO NOT TOW MORE THAN ONE SOLORIDER VEHICLE WITH ANOTHER GOLF CAR. IF MORE THAN ONE VEHICLE MUST BE TOWED, AN ADEQUATELY POWERED VEHICLE (TRACTOR OR FULL SIZED TRUCK) PROPERLY FITTED, WITH A TOW HITCH HEIGHT OF 11 INCHES (28CM) SHOULD BE USED. ONLY HEAVY-DUTY TOW BARS SHOULD BE USED FOR MULTI-VEHICLE TOWING. NEVER TOW MORE THAN FIVE VEHICLES AT ONE TIME.
- PLACE THE TOW/OFF/RUN SWITCH IN **TOW** POSITION TO RELEASE THE PARKING BRAKE. THE VEHICLE WILL NOT ROLL OTHERWISE.

All vehicles are equipped with both front and rear tow bar attaching points. A tow bar is available for breakdown towing and single vehicle towing. Observe all of the previous WARNING statements when towing.

Transporting on a Trailer

If your vehicle must be transported over long distances or on public highways, it should be done on an approved trailer, and all the following WARNING procedures should be followed:

WARNING

- FOR USE ON PUBLIC ROADS, THE TRAILER MUST MEET ALL FEDERAL, STATE AND LOCAL REQUIREMENTS SUCH AS TAIL LIGHTS, BRAKE LIGHTS, ETC....
- ALWAYS USE AN APPROVED TRAILER THAT HAS A LOAD RATING OF 1000 LB. PER VEHICLE TO BE TOWED. (EXAMPLE: A TWO-CAR TRAILER SHOULD BE RATED AT 2 X 1000 = 2000 LB.).
- NEVER TOW A SOLORIDER VEHICLE BEHIND A PASSENGER VEHICLE OR TRUCK ON A PUBLIC ROAD UNLESS IT IS ON AN APPROVED TRAILER.
- THE VEHICLE TO BE TOWED SHOULD BE TIED SECURELY TO THE TRAILER, WITH THE KEY SWITCH **OFF**, AND THE TOW/OFF/RUN SWITCH IN EITHER **OFF** OR **RUN** POSITION.
- DO NOT ALLOW PEOPLE IN THE TRAILER OR VEHICLE BEING TOWED.
- AVOID SUDDEN STARTS, SUDDEN STOPS AND TIGHT TURNS WHEN TOWING.
- AVOID STOPPING ON A HILL WHEN TOWING. IF YOU MUST STOP ON A HILL, AVOID SUDDEN STARTS OR ROLLING BACKWARDS AND STOPPING SUDDENLY. FAILURE TO HEED THIS WARNING COULD CAUSE THE VEHICLE TO OVERTURN, POSSIBLY RESULTING IN SEVERE PERSONAL INJURY.
- WHEN TOWING ON A TRAILER, NORMAL ROAD SPEED OF THE TOW VEHICLE SHOULD BE REDUCED.
- BECAUSE OF THE ADDED LENGTH OF THE TRAILER, CAUTION SHOULD BE USED WHEN TURNING A CORNER.
- REMOVE THE VEHICLE CANOPY TOP BEFORE TRANSPORTING ON A TRAILER.

Storage

Read DANGER and WARNING on page 7.

⚠ WARNING

- TURN KEY SWITCH TO OFF, REMOVE KEY, AND PLACE TOW/OFF/RUN SWITCH IN **OFF** POSITION. THIS IS TO PREVENT UNINTENTIONALLY STARTING THE VEHICLE OR A FIRE HAZARD.
- DO NOT ATTEMPT TO CHARGE FROZEN BATTERIES WITH BULGED CASES. DISCARD THE BATTERIES. FROZEN BATTERIES CAN EXPLODE.

⚠ CAUTION

- BATTERIES IN LOW STATE OF CHARGE WILL FREEZE AT LOW TEMPERATURES.
- WHEN WASHING THE VEHICLE, DO NOT DIRECT WATER STREAM AT THE ACCELERATOR SWITCH, FORWARD/REVERSE SWITCH, ONBOARD CONTROLLER, OR OTHER ELECTRICAL COMPONENTS.
- IF BATTERY WIRE TERMINALS ARE DAMAGED OR CORRODED, THEY SHOULD BE REPLACED OR CLEANED AS NECESSARY. FAILURE TO DO SO MAY CAUSE THEM TO OVERHEAT DURING OPERATION.

Fully charge batteries. See Batteries Page 22.

Wash off any corrosion around the terminals with a solution of baking soda and water (one cup per gallon of water), then rinse solution from the batteries (do NOT allow this solution to enter the batteries). Let the terminals dry and coat them with the Battery Terminal Spray.

Store in a cool, dry place. This will minimize self-discharge of the batteries.

Adjust tire pressure to 17-20 psi.

Grease front suspension and do all other semi-annual periodic lubrication. See Periodic Lubrication Schedule, Page 21.

Thoroughly clean front body, rear body, seats, battery compartment, and underside of vehicle.

Keep batteries fully charged during storage. See Batteries, Page 23.

⚠ CAUTION

DO NOT ALLOW BAKING SODA TO ENTER THE BATTERIES.

NOTE

IF THE CHARGER CANNOT REMAIN PLUGGED IN DURING LONG TERM STORAGE, DISCONNECT BATTERY CABLES.

To Return the Stored Vehicle to Service

Fully charge the Batteries. See Batteries, Page 22.

Readjust tire pressure to 18-20 psi (124-138kPa).

Perform the Pre-Operation Checklist. See page 10.

Maintenance

Read **DANGER** and **WARNING** on Page 7.

GENERAL INFORMATION

To ensure trouble-free vehicle performance, it is very important to follow an established preventive maintenance program (regularly scheduled service, even though the vehicle is functional). Regular and consistent vehicle maintenance can prevent vehicle downtime and expensive repairs that result from neglect. Any vehicle not functioning correctly should be removed from use until it is properly repaired. This will prevent further damage to the vehicle and avoid the possibility of injury due to unsafe conditions. Contact your local SoloRider distributor/dealer to perform all repairs and semi-annual and annual periodic service. See the following **WARNING**.

WARNING

- IF PROBLEMS ARE FOUND DURING SCHEDULED INSPECTION OR SERVICE, DO NOT OPERATE THE VEHICLE UNTIL REPAIRS ARE MADE. FAILURE TO MAKE NECESSARY REPAIRS COULD RESULT IN FIRE, PROPERTY DAMAGE, SEVERE PERSONAL INJURY, OR DEATH.
- **HOT!** DO NOT ATTEMPT TO SERVICE HOT MOTOR OR CONTROLLER. ATTEMPTING DO SO COULD CAUSE SEVERE BURNS.

Daily Pre-Operation Safety Checklist

Inspect and drive the vehicle, using the Pre-operation Checklist (Page 10) and Performance Inspection (Page 10) as a guide to check the following items.

Vehicle warning decals
Parking brake
Reverse warning buzzer
Steering and linkages
Proper acceleration and maximum speed
Batteries
Accelerator switch

In addition, check the items listed below:

Tires: Visually inspect for wear, damage, and proper inflation.

Forward/Reverse switch: Check for proper operation. See Controls and Indicators, Page 11.

Charger cord, plug, and receptacle. See Plug and Receptacle, Page 27.

Periodic Service and Schedule

WARNING

- SERVICE, REPAIRS, AND ADJUSTMENTS MUST BE MADE PER INSTRUCTIONS IN THE MAINTENANCE AND SERVICE MANUAL.

NOTE

- IF THE VEHICLE IS CONSTANTLY SUBJECTED TO HEAVY USE OR SEVERE OPERATING CONDITIONS, THE PREVENTIVE MAINTENANCE PROCEDURE SHOULD BE PERFORMED MORE OFTEN THAN RECOMMENDED IN THE SERVICE AND LUBRICATION SCHEDULES.
- BOTH THE PERIODIC SERVICE SCHEDULE AND PERIODIC LUBRICATION SCHEDULE MUST BE FOLLOWED TO KEEP VEHICLE IN OPTIMUM OPERATING CONDITION.

PERIODIC SERVICE SCHEDULE

REGULAR INTERVAL

SERVICE

Daily Service by Owner

Batteries

Charge batteries (after every use).

Weekly Service by Owner

Batteries

Check electrolyte level. Add water as

		Necessary per the maintenance and service supplement.
Monthly Service by Owner Or Trained Technical	Batteries	Wash battery tops and clean terminals with soda/water solution. Dispose of waste water properly.
	Tires	Check air pressure and adjust as necessary. See Vehicle Capacities Chart on Page 22
	General	Wash battery compartment and underside of vehicle. Dispose of waste water properly.
	E-Stop	Cycle switch and ensure proper operation. If equipped.
Semi-annual Service by Trained Technician ONLY (Every 50 hours of operation or 100 rounds of golf.	Brake System Electrical Wiring & Connections	Check Brake Shoes; replace if necessary. See the maintenance and service manual. Check for tightness and damage.
	Front Wheel Alignment	Check and adjust as required. See the maintenance and service manual.
Annual service by Trained Technician ONLY (Every 100 hours of operation or 200 rounds of golf)	Batteries	If batteries are not performing expected.

⚠ WARNING

IF ANY PROBLEMS ARE FOUND, DO NOT OPERATE THE VEHICLE UNTIL REPAIRS ARE MADE. FAILURE TO MAKE NECESSARY REPAIRS COULD RESULT IN FIRE, PROPERTY DAMAGE, SEVERE PERSONAL INJURY, OR DEATH.

PERIODIC LUBRICATION SCHEDULE

REGULAR INTERVAL	SERVICE	PLACE	RECOMMENDED LUBRICANT
Semi-Annually by Owner or Trained Technician (Every 50 Hours of operation or every 100 rounds of golf)		Accelerator cable attachment to PB6	1. Dry Moly Lube
		Charger Receptacle	2. WD 40

	Front Suspension	3.	Chassis Lube – EP NLGI Grade 2
Annually by Trained Technician ONLY (Every 100 hours of operation or 200 rounds of golf)	Drain/Fill transaxle	4.	22 oz. (.67 liter) SAE WT. API Class SE, SF, or SG Oil (or higher)
	Inspect Front wheel Bearings (Repack as Necessary)	5.	Chassis Lube –EP NLGI Grade 2

Vehicle Lubrications Points

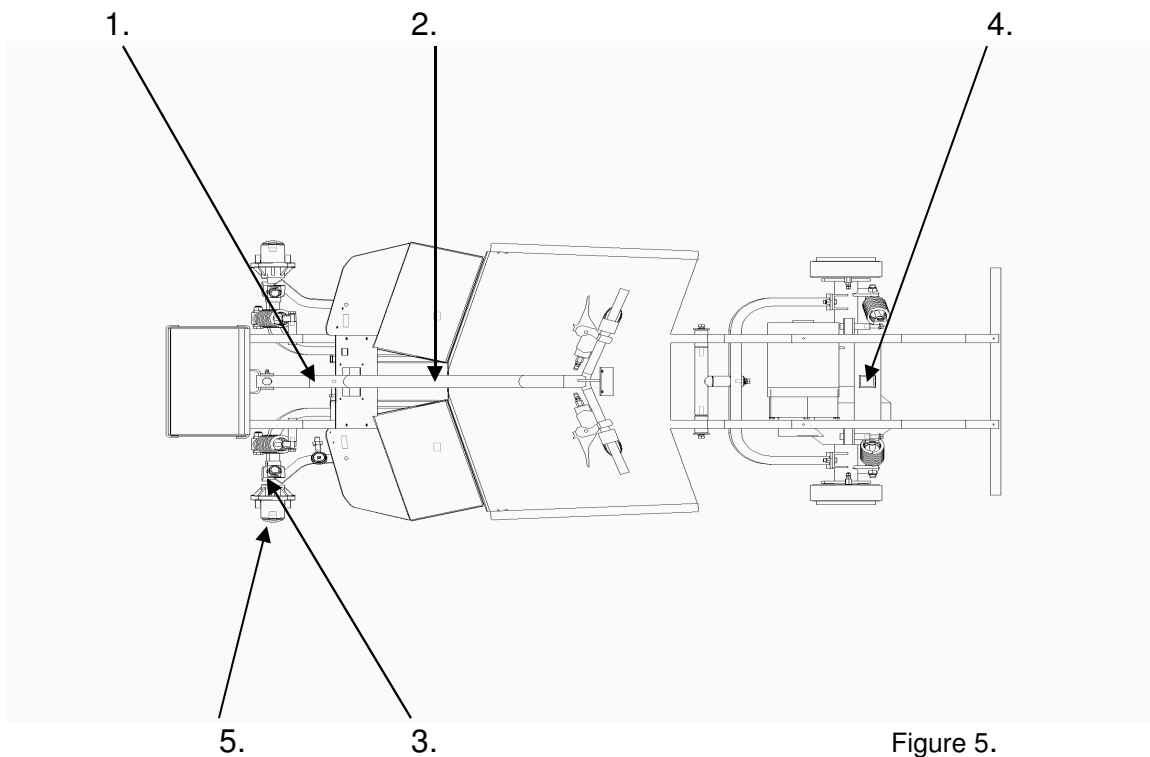

Figure 5.

Vehicle Capacities

CAPACITIES

Transaxle	22 oz. (.67 liters)
Tire Pressure	18-20 psi (124-138 kPa)

Vehicle Controller

The vehicle is equipped with a Solid State Speed Controller.

In order to properly service and maintain the Solid State Controller vehicle, it is necessary to understand the electrical circuitry and the functions of all components in the system. Therefore, if any repair or servicing needs to be performed, we recommend that it be performed by an authorized SoloRider distributor/dealer using SoloRider OEM parts.

Batteries

Read DANGER and WARNING on page 7.

DANGER

BATTERY – EXPLOSIVE GASES! DO NOT SMOKE! KEEP SPARKS AND FLAMES AWAY FROM VEHICLE AND SERVICE AREA. TOOLS, WIRES, AND METAL OBJECTS CAN CAUSE SPARKS WHEN SHORTED ACROSS A BATTERY. FOLLOW ALL INSTRUCTIONS CAREFULLY WHEN DEALING WITH BATTERIES.

CHARGE BATTERIES IN A WELL-VENTILATED AREA ONLY. BATTERIES EMIT HYDROGEN WHILE BEING CHARGED. HYDROGEN IS AN EXPLOSIVE GAS AND MUST NEVER EXCEED A LEVEL OF 2% OF THE AIR.

POISON! CONTAINS ACID! CAUSES SEVERE BURNS – AVOID CONTACT WITH SKIN, EYES, OR CLOTHING. ANTIDOTES:

EXTERNAL: FLUSH WITH WATER FOR 15 MINUTES. *CALL A PHYSICIAN IMMEDIATELY.*

INTERNAL: DRINK LARGE QUANTITIES OF MILK OR WATER FOLLOWED WITH MILK OF

MAGNESIA OR VEGETABLE OIL. *CALL A PHYSICIAN IMMEDIATELY.*

EYES: FLUSH WITH WATER FOR 15 MINUTES. *CALL A PHYSICIAN IMMEDIATELY.*

WARNING

- WEAR SAFETY GLASSES OR APPROVED EYE PROTECTION WHEN SERVICING THE VEHICLE. WEAR A FULL FACE SHIELD AND RUBBER GLOVES WHEN WORKING WITH BATTERIES.
- USE INSULATED TOOLS WHEN WORKING AROUND BATTERIES OR ELECTRICAL CONNECTIONS.

CAUTION

- ON ALL VEHICLES, TURN OFF ALL ACCESSORIES BEFORE CHARGING BATTERIES.

NOTE

- RECYCLE OR DISPOSE OF DISCARDED BATTERIES IN ACCORDANCE WITH LOCAL, STATE, AND FEDERAL REGULATIONS.

The batteries are 12 Volts each, and are deep cycle batteries, specially built for electric vehicle application. Automotive batteries should never be used.

New batteries will not deliver their full capabilities until they have been discharged and recharged 20 to 50 times. To obtain the maximum service life from new batteries, restrict vehicles with new batteries to 18 holes of use between charges n the first two months of operation. Batteries should be fully charged before first use of new vehicle, before first use of a vehicle after storage, and before releasing vehicle for use each day.

Battery Care

To keep batteries in good working condition, follow this maintenance program on a regular basis:

The batteries should be kept clean and free of corrosion. Wash tops and terminals of batteries with a solution of baking soda and water (1 cup baking soda per 1 gallon of water) once per week. Rinse solution off of the batteries. See following NOTE.

NOTE

- DO NOT ALLOW BAKING SODA SOLUTION TO ENTER THE BATTERY.
- DISPOSE OF WASTE WATER PROPERLY.

Be sure terminals are tight. Let the terminals dry and then spray them with Battery Protector Spray.

The electrolyte level in the batteries should be checked weekly (see figure 6 for proper level). Add the water only after charging unless the electrolyte level is below the top of the plates. In this case, add just enough water to cover the plates, charge and then check the level again. Never charge batteries if plates are exposed above electrolyte level. For best battery life, add only distilled water. See following NOTE.

NOTE

- A BATTERY WATERING GUN OR BOTTLE IS AVAILABLE AT REGAL RESEARCH OR MANY AUTO PART DEALERS.

The hold-down straps should be tight enough so that the batteries do not move while the vehicle is in motion, but not so tight as to crack or buckle the battery case. Tighten hold-down retaining nuts to 40 in-lb. (4.5 N.m). The terminal connections should be clean and tight, and any worn insulation or frayed wires should be replaced. Tighten battery terminals to 110 in/lbs. (12.4 N.m). See following CAUTION.

⚠ CAUTION

IF BATTERY WIRE TERMINALS ARE DAMAGED OR CORRODED, THEY SHOULD BE REPLACED OR CLEANED AS NECESSARY. FAILURE TO DO SO MAY CAUSE THEM TO OVERHEAT DURING OPERATION.

After use, the batteries should be placed on charge. The batteries should never be left discharged any longer than absolutely necessary (do not leave discharged overnight).

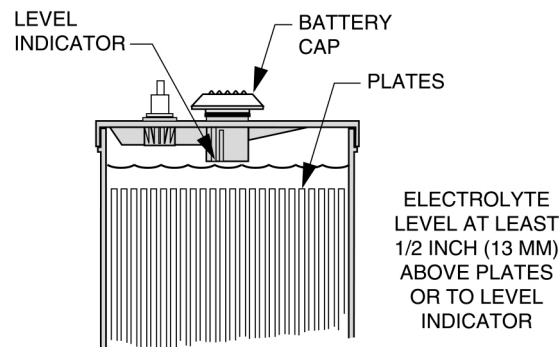

Figure 6

Battery Charger

⚠ DANGER

- BATTERIES EMIT HYDROGEN WHILE BEING CHARGED. HYDROGEN IS AN EXPLOSIVE GAS. IF THE VEHICLE IS EQUIPPED WITH A WEATHERPROOF ENCLOSURE, IT SHOULD BE UNZIPPED AND PULLED BACK WHILE BATTERIES ARE BEING CHARGED. THIS IS TO AVOID THE ACCUMULATION OF HYDROGEN GAS INSIDE THE ENCLOSURE.
- THE CHARGING AREA MUST BE VENTILATED. HYDROGEN LEVEL IN THE AIR MUST NEVER EXCEED 2%. THE TOTAL VOLUME OF AIR IN THE BUILDING MUST

BE CHANGED FIVE TIMES PER HOUR. EXHAUST FANS SHOULD BE LOCATED AT THE HIGHEST POINT OF THE ROOF. CONTACT A LOCAL HVAC ENGINEER.

⚠ WARNING

- ONLY TRAINED TECHNICIANS SHOULD REPAIR OR SERVICE THE CHARGER. CONTACT YOUR NEAREST SOLORIDER DISTRIBUTOR/DEALER.
- EACH CHARGER SHOULD HAVE ITS OWN DEDICATED 15 OR 20 AMPERE SEPARATELY PROTECTED (CIRCUIT BREAKER OR FUSE) SINGLE PHASE BRANCH CIRCUIT, IN ACCORDANCE WITH ALL APPLICABLE ELECTRICAL CODES FOR THE LOCATION.
- CONNECT THE CHARGER AC SUPPLY CORD TO A PROPERLY GROUNDED, THREE-WIRE OUTLET OF THE PROPER VOLTAGE AND FREQUENCY AS SHOWN ON THE CHARGER.

- DO NOT USE AN ADAPTER TO PLUG THE CHARGER WITH A THREE-PRONG PLUG INTO A TWO PRONG OUTLET. IMPROPER CONNECTION OF THE EQUIPMENT-GROUNDING CONDUCTOR CAN RESULT IN A FIRE OR AN ELECTRICAL SHOCK.
- AN EXTENSION CORD OR ELECTRICAL OUTLET MUST ACCEPT A THREE-PRONG PLUG. EXTENSION CORD SHOULD BE A THREE-WIRE NO. 12 AWG, AND BE AS SHORT AS POSSIBLE. THE USE OF IMPROPER EXTENSION CORD COULD RESULT IN FIRE OR AN ELECTRICAL SHOCK.
- DO NOT OPERATE THE CHARGER IF IT HAS RECEIVED A SHARP BLOW, WAS DROPPED, OR OTHERWISE DAMAGED IN ANY WAY.
- HAVE WORN, CUT, OR DAMAGED POWER CORDS OR WIRES REPLACED IMMEDIATELY.
- DO NOT USE NEAR FUELS, GRAIN DUST, SOLVENTS, THINNERS, OR OTHER FLAMMABLES.
- CHARGERS CAN IGNITE FLAMMABLE MATERIALS AND VAPORS.
- DO NOT EXPOSE TO RAIN OR ANY LIQUID. KEEP THE CHARGER DRY.
- NEVER PUSH OBJECTS OF ANY KIND INTO THE CHARGER THROUGH CABINET SLOTS. THEY MAY TOUCH DANGEROUS VOLTAGE POINTS OR CAUSE AN ELECTRICAL SHORT CIRCUIT THAT COULD RESULT IN FIRE OR ELECTRICAL SHOCK.
- DO NOT CONNECT A STATIONARY CHARGER TO THE RECEPTACLE IF THE CHARGER CORD, PLUG OR THE VEHICLE RECEPTACLE IS BROKEN, DAMAGED, OR DOES NOT MAKE A GOOD ELECTRICAL CONNECTION. FIRE OR PERSONAL INJURY CAN RESULT. HAVE A QUALIFIED TECHNICIAN REPLACE THE PARTS.
- DO NOT DISCONNECT THE DC OUTPUT PLUG FROM THE VEHICLE RECEPTACLE WHEN THE CHARGER IS ON. THE RESULTING ARCING AND BURNING COULD DAMAGE THE PLUG AND RECEPTACLE AND COULD CAUSE BATTERIES TO EXPLODE. IF THE CHARGER MUST BE STOPPED, DISCONNECT THE AC SUPPLY PLUG FROM THE WALL OUTLET BEFORE DISCONNECTING THE CHARGER DC CORD FROM THE VEHICLE RECEPTACLE.

CAUTION

- DO NOT BLOCK OR COVER SLOTS AND OPENINGS IN THE BACK AND BOTTOM OF CHARGER CABINET. THEY PROVIDE VENTILATION AND PROTECT THE CHARGER FROM OVERHEATING.
- DO NOT ALLOW CLOTHING, BLANKETS, OR OTHER MATERIAL TO COVER THE CHARGER.
- PROVIDE ADEQUATE VENTILATION FOR THE CHARGER.
- DO NOT LEAVE THE DC CORD PLUGGED INTO A VEHICLE RECEPTACLE WHILE UNATTENDED FOR MORE THAN TWO CONSECUTIVE DAYS. SEVERE

OVERHEATING AND DAMAGE TO THE BATTERIES MAY RESULT IF THE CHARGER DOES NOT TURN OFF.

- INSTALL SURGE ARRESTORS IN INCOMING AC POWER LINES. SURGE ARRESTORS WILL HELP PROTECT ELECTRICAL/ELECTRONIC COMPONENTS IN THE CHARGER AND ON THE VEHICLE FROM ALL BUT DIRECT OR VERY CLOSE LIGHTNING STRIKES.

Each electric vehicle is supplied with a fully automatic battery charger as standard equipment. The AC cord to each charger is to be connected to a source capable of supplying 10 amperes minimum per charger.

The battery charger must be grounded to reduce the risk of electrical shock. The charger is equipped with an AC electric cord having an equipment-ground conductor and grounding type plug. The plug must be grounded in accordance with the National Electrical Code, ANSI/NFPA 70, and all local codes and ordinances. See the owner's manual supplied with the charger for specific operating instructions before using the charger.

The use of an extension cord with the charger should be avoided. If an extension cord must be used, a three conductor No.12 AWG heavy-duty cord with a ground conductor in good electrical condition must be used. Keep it as short as possible (no more than twelve feet (3.7 m)). Locate all cords so that they will not be stepped on, tripped over, or otherwise subject to damage or stress.

Ventilation fans should be located at the highest point in the room and must be capable of changing the total volume of air in the room five (5) times per hour. Consult a local HVAC engineer.

To Charge Batteries

WARNING

- BE SURE ALL WIRE CONNECTIONS AT THE RECEPTACLE AND THE FUSE LINK ARE CLEAN AND TIGHT.
- DO NOT ROCK OR BEND THE PLUG. TO CONNECT THE CHARGER PLUG TO THE VEHICLE RECEPTACLE, GRASP THE PLUG HANDLE AND PUSH THE PLUG STRAIGHT INTO THE RECEPTACLE. (Figure 7).
- DO NOT PUSH ON THE DC CORD (Figure 8). DO NOT TWIST, ROCK OR BEND THE PLUG. TO DISCONNECT THE CHARGER PLUG FROM THE VEHICLE

RECEPTACLE, GRASP THE PLUG BY THE HANDLE AND PULL THE PLUG STRAIGHT OUT OF THE RECEPTACLE.

- DO NOT CONNECT A CHARGER TO THE RECEPTACLE IF THE CHARGER CORD, PLUG OR THE VEHICLE RECEPTACLE IS BROKEN, DAMAGED IN ANY MANNER, OR DOES NOT MAKE A GOOD ELECTRICAL CONNECTION. FIRE OR PERSONAL INJURY CAN RESULT. HAVE IT REPLACED BY A QUALIFIED SERVICE PERSON IMMEDIATELY.
- FAILURE TO FOLLOW THESE INSTRUCTIONS COULD RESULT IN DAMAGE TO THE CHARGER CORD, THE PLUG, AND (OR) THE VEHICLE RECEPTACLE.
- **DO NOT USE A CHARGER IF:**

THE PLUG IS TOO LOOSE OR DOES NOT MAKE A GOOD CONNECTION.
THE PLUG AND RECEPTACLE FEEL HOTTER THAN NORMAL DURING CHARGE.
THE PLUG BLADES OR RECEPTACLE CONTACTS ARE BENT OR CORRODED.
THE PLUG, RECEPTACLE, OR CORDS ARE CUT, WORN, HAVE ANY EXPOSED WIRES OR ARE DAMAGED IN ANY WAY.

USING THE CHARGER WITH ANY OF THE ABOVE SYMPTOMS COULD RESULT IN A FIRE, PROPERTY DAMAGE, PERSONAL INJURY, OR DEATH.

- PUSH THE E-STOP SWITCH (OPTIONAL) (Figure 2A) WHEN CHARGING TO ENSURE THAT THE CAR WILL NOT INADVERTENTLY BE DRIVEN AWAY WHILE CONNECTED TO THE BATTERY CHARGER.

NOTE

- WHEN TEMPERATURES FALL BELOW 65 F (18.9°C), BATTERIES CHARGED IN UNHEATED AREAS SHOULD BE PLACED ON CHARGE AS SOON AS POSSIBLE AFTER USE. BATTERIES ARE WARMEST IMMEDIATELY AFTER USE, AND COLD BATTERIES REQUIRE MORE TIME TO FULLY CHARGE.

Insert the charger DC plug into the vehicle receptacle. The charger will turn on two to ten seconds later (Figure 7). As long as the charger is allowed to shut off by itself, the batteries will be fully charged. Over charging and undercharging normally will be prevented. Batteries should be put on charge even if they have been used for only a short period (9 holes of golf or 10 minutes). The charger is automatic and will turn off when batteries are fully charged. If the charger does not seem to be operating properly, or if the batteries seem weak, contact your local SoloRider distributor/dealer.

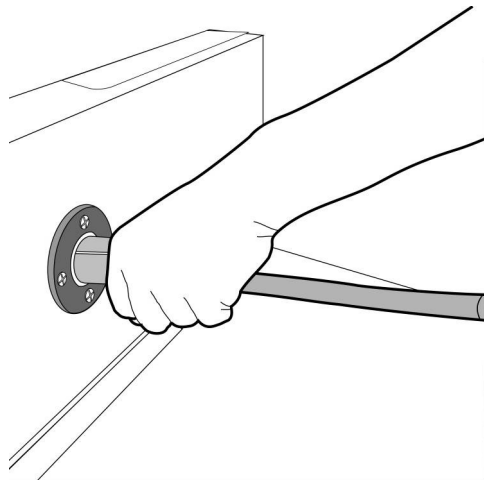

Figure 7
Correct Insertion of Charger DC Plug

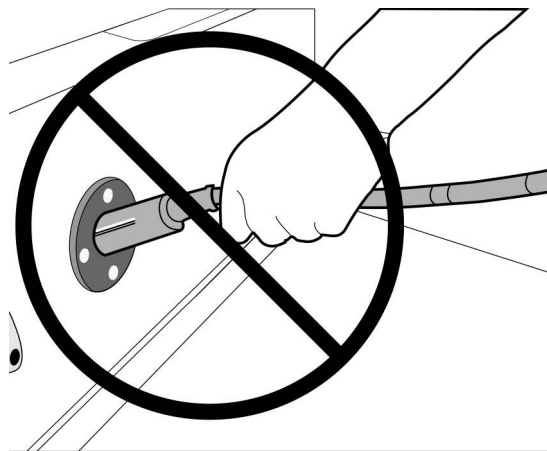

Figure 8
Incorrect Insertion of Charger DC Plug

Plug and Receptacle

The charger cord, plug, and receptacle are wear items and should be inspected daily. Visually inspect them for cracks, loose connections, and frayed wiring; they must be replaced when worn or damaged. If the charger plug and receptacle show signs of corrosion or are difficult to insert and remove, the receptacle contacts and plug blades/pins may be cleaned with a good electrical contact cleaner or lightly sprayed with WD-40 brand spray lubricant. The plug then should be inserted and removed several times to ensure ease of insertion, ease of removal, and good electrical contact. See following NOTE.

NOTE

- IF THE WARNING TAG HAS BEEN DAMAGED OR REMOVED FROM THE DC CORD, HAVE IT REPLACED IMMEDIATELY.

Receptacle Fuse Link

As an additional feature to protect the batteries and charging circuit from an overload, the electric vehicle is equipped with a receptacle fuse link (Figure 9). If the charger does not come on when the vehicle is placed on charge, visually inspect the fuse link. See following WARNING.

⚠ WARNING

IF THE RECEPTACLE FUSE LINK IS BLOWN, DETERMINE THE SOURCE OF THE ELECTRICAL PROBLEM AND CORRECT IT BEFORE REPLACING THE FUSE. CONTACT YOUR NEAREST SOLORIDER DISTRIBUTOR/DEALER.

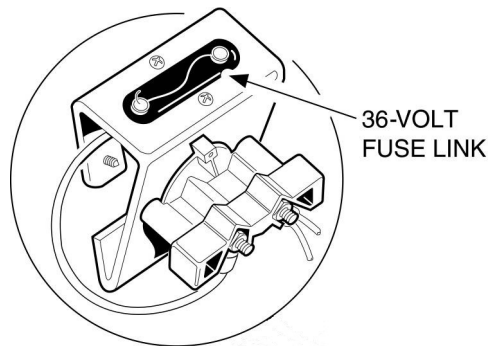

Figure 9

Receptacle Fuse Link for 36-Volt Vehicle

Cleaning the Vehicle

SoloRider vehicles are equipped with ABS front and rear bodies. Use only commercially available automotive cleaners with a sponge or soft cloth for normal cleaning. A garden hose at normal residential water pressure is adequate.

Solorider does not recommend any type of pressure washing or steam cleaning. Such a process (especially if the front body is removed or opened) will expose electrical components to moisture. Moisture entering electrical components can result in water damage and subsequent component failure.

Use non-abrasive wax products. Battery acid, fertilizers, tars, asphalt, creosote, paint, or chewing gum should be removed immediately to prevent possible stains.

The seats of the vehicle will last longer with proper cleaning. Use a solution of 10% liquid soap and warm water applied with a soft cloth. For imbedded dirt, a soft bristle brush may be used. For heavy soiling, difficult stains or scratches, blemishes, or other body damage, see Section 4 of the appropriate maintenance and service manual.

NOTE

- DISPOSE OF WASTE WATER PROPERLY.

Accessories

There is a complete line of accessory equipment available from SoloRider and our distributor/dealers.

Care should be taken that trained technicians properly install these accessories, and that they are used in the manner for which they were designed. See following WARNING.

WARNING

TINTED WINDSHIELDS AND WEATHER-PROOF ENCLOSURES WILL NOT PROTECT OCCUPANTS FROM FLYING OBJECTS (GOLF BALLS, ETC.).

ACCESSORY EQUIPMENT

Standard Tread Tires

Dual-bag rack

Rear View Mirrors

Sand Bottle Divot Repair Kit

Lighting Package (headlights, taillights, brake lights, turn signals, and horn)

Subsequent Owner Registration

In the event a vehicle is purchased as a used vehicle from another individual or from a distributor/dealer, we strongly urge the new owner to re-register the vehicle with Regal Research. This will enable us to contact you if the need arises. Please send your name, address, and serial number (s) of the vehicle (s) to Regal Research and Mfg. Co., PO Box 940529, Plano, TX 75094-0529, Attn: Vehicle Registration.

SoloRider Technical Specifications

STEERING/SUSPENSION/BRAKES

Steering: Single tiller with direct linkage to front wheels

Suspension: Automotive type front and rear coil springs with hydraulic shocks.

Brakes: Dual rear wheel hydraulic self-adjusting brakes with cast iron drums.

Parking Brake: Spring applied disc brake, controlled by on-board microprocessor controller.

BODY/CHASSIS

Frame/Chassis: Tubular steel with powder-coated finish.

Front and Rear Body: ABS/Solarkote.

Body Finish: Molded-in color.

Tires: 18 x 8.50 – 8 tubeless, 4 ply rated.

SEATING CAPACITY

Seating capacity:

1 person ONLY, maximum weight 350 lbs.

DIMENSIONS/WEIGHT

Overall Length	85.0 in.
Overall Width	39.0 in.
Overall Height: With Canopy	72.0 in.
Overall Height: At Steering Tiller	45.0 in.
Wheelbase	54.0 in.
Ground Clearance	6.0 in.
Front Wheel Tread	29.0 in.
Rear Wheel Tread	29.0 in.
Weight: Standard electric vehicle (without batteries)	498 lb.
Forward Speed	11-14 mph.
Curb Clearance Circle (diameter)	18 ft.
Braking Distance: At 12 mph	14 ft.